

Part number:

49001-2501

Copyright

© 2014, FLIR Systems, Inc.

All rights reserved worldwide. Names and marks appearing herein are either registered trademarks or trademarks of FLIR Systems and/or its subsidiaries. All other trademarks, trade names or company names referenced herein are used for identification only and are the property of their respective owners.

February 03, 2014, 01:15 PM

Corporate Headquarters

FLIR Systems, Inc.
27700 SW Parkway Ave.
Wilsonville, OR 97070
USA
Telephone: +1-503-498-3547

Website

<http://www.flir.com>

Customer support

<http://support.flir.com>

Legal disclaimer

Specifications subject to change without further notice. Camera models and accessories subject to regional market considerations. License procedures may apply.

Information and equipment described herein may require US Government authorization for export purposes. Diversion contrary to US law is prohibited.



Imaging and optical data

IR resolution	240 × 180 pixels
Thermal sensitivity/NETD	< 0.045°C @ +30°C (+86°F) / 45 mK
Field of view (FOV) / Minimum focus distance	25° × 19° / 0.4 m (1.31 ft.)
Spatial resolution (IFOV)	1.82 mrad
Image frequency	60 Hz
Focus	Manual
Zoom	2× and 4× digital zoom, including panning
Focal Plane Array (FPA) / Spectral range	Uncooled microbolometer / 7.5–13 μm

Image presentation

Display	Touch screen, 3.5 in. LCD, 320 × 240 pixels
Image modes	IR image, visual image, thermal fusion, picture in picture, thumbnail gallery
Thermal fusion	IR image shown above, below or within temp interval on visual image
Picture in Picture	Scalable IR area on visual image

Measurement

Object temperature range	-20°C to +120°C (-4°F to +248°F)
Accuracy	±2°C (±3.6°F) or ±2% of reading, for ambient temperature 10°C to 35°C (+50°F to 95°F)

Measurement analysis

Spotmeter	3
Area	3 boxes with max./min./average
Automatic hot/cold detection	Auto hot or cold spotmeter markers within area
Isotherm	Detect high/low temperature/interval
Difference temperature	Delta temperature between measurement functions or reference temperature
Emissivity correction	Variable from 0.01 to 1.0 or selected from materials list
Measurement corrections	Reflected temperature, optics transmission and atmospheric transmission

Alarm

Humidity alarm	1 humidity alarm, including dew point alarm
Insulation alarm	1 insulation alarm

P/N: 49001-2501

© 2014, FLIR Systems, Inc.
All rights reserved worldwide.

Set-up	
Color palettes	Arctic, Gray, Iron, Lava, Rainbow and Rainbow HC
Set-up commands	Local adaptation of units, language, date and time formats
Languages	21
Storage of images	
Image storage	Standard JPEG, including measurement data, on memory card
Image storage mode	IR/visual images; simultaneous storage of IR and visual images
Image annotations	
Voice	60 seconds (via Bluetooth)
Text	Text from predefined list or soft keyboard on touch screen
Meterlink	Wireless connection (Bluetooth®) to: Extech Moisture Meter MO297 Extech Clamp Meter EX845
Report generation	<ul style="list-style-type: none"> Separate PC software with extensive report generation
Video recording in camera	
Non-radiometric IR-video recording	MPEG-4 to memory card
Video streaming	
Radiometric IR-video streaming	Full dynamic to PC using USB
Non-radiometric IR-video streaming	Uncompressed colored video using USB
Digital camera	
Built-in digital camera	3.1 Mpixel (2048 × 1536 pixels), and one LED light
Built-in digital lens data	FOV 53° × 41°
Laser pointer	
Laser	Activated by dedicated button
Laser alignment	Position is automatic displayed on the IR image
Data communication interfaces	
Interfaces	USB-mini, USB-A, Bluetooth, Wi-Fi, composite video
Bluetooth	Communication with headset and external sensors
Wi-Fi	Peer to peer (ad hoc) or infrastructure (network)
USB	<ul style="list-style-type: none"> USB-A: Connect external USB device USB Mini-B: Data transfer to and from PC / Uncompressed colored video
Video out	Composite
Radio	
Wi-Fi	Standard: 802.11 b/g Frequency range: 2412–2462 MHz Max output power: 15 dBm
Bluetooth	Frequency range: 2402–2480 MHz
Antenna	Internal
Power system	
Battery	Li Ion, 4 hours operating time
Charging system	In camera (AC adapter or 12 V from a vehicle) or 2-bay charger
Charging temperature	0°C to +45°C (+32°F to +113°F)
Power management	Automatic shutdown and sleep mode (user selectable)
Environmental data	
Operating temperature range	-15°C to +50°C (+5°F to +122°F)

P/N: 49001-2501

© 2014, FLIR Systems, Inc.
All rights reserved worldwide.

Environmental data

Storage temperature range	-40°C to +70°C (-40°F to +158°F)
Humidity (operating and storage)	IEC 60068-2-30/24 h 95% relative humidity +25°C to +40°C (+77°F to +104°F) / 2 cycles
EMC	<ul style="list-style-type: none">• ETSI EN 301 489-1 (radio)• ETSI EN 301 489-17• EN 61000-6-2 (Immunity)• EN 61000-6-3 (Emission)• FCC 47 CFR Part 15 B (Emission)• ICES-003
Radio spectrum	<ul style="list-style-type: none">• ETSI EN 300 328• FCC Part 15.247• RSS-210
Encapsulation	IP 54 (IEC 60529)
Bump	25 g (IEC 60068-2-29)
Vibration	2 g (IEC 60068-2-6)
Drop	2 m (6.6 ft.)
Safety	EN/UL/CSA/PSE 60950-1

Physical data

Camera weight, incl. battery	0.865 kg (1.91 lb.)
Camera size (L x W x H)	246 x 97 x 184 mm (9.7 x 3.8 x 7.2 in.)
Tripod mounting	UNC ¼"-20 (adapter needed)

Shipping information

- Hard transport case
 - Infrared camera with lens
 - Battery
 - Calibration certificate
 - Camera lens cap
 - Downloads brochure
 - FLIR Tools software
 - Handstrap
 - Memory card
 - Power supply, incl. multi-plugs
 - Printed Getting Started Guide
 - Printed Important Information Guide
 - Service & training brochure
 - USB cable
 - User documentation CD-ROM
 - Video cable
 - Warranty extension card
-

Camera with built-in IR lens f=18 mm (25°)

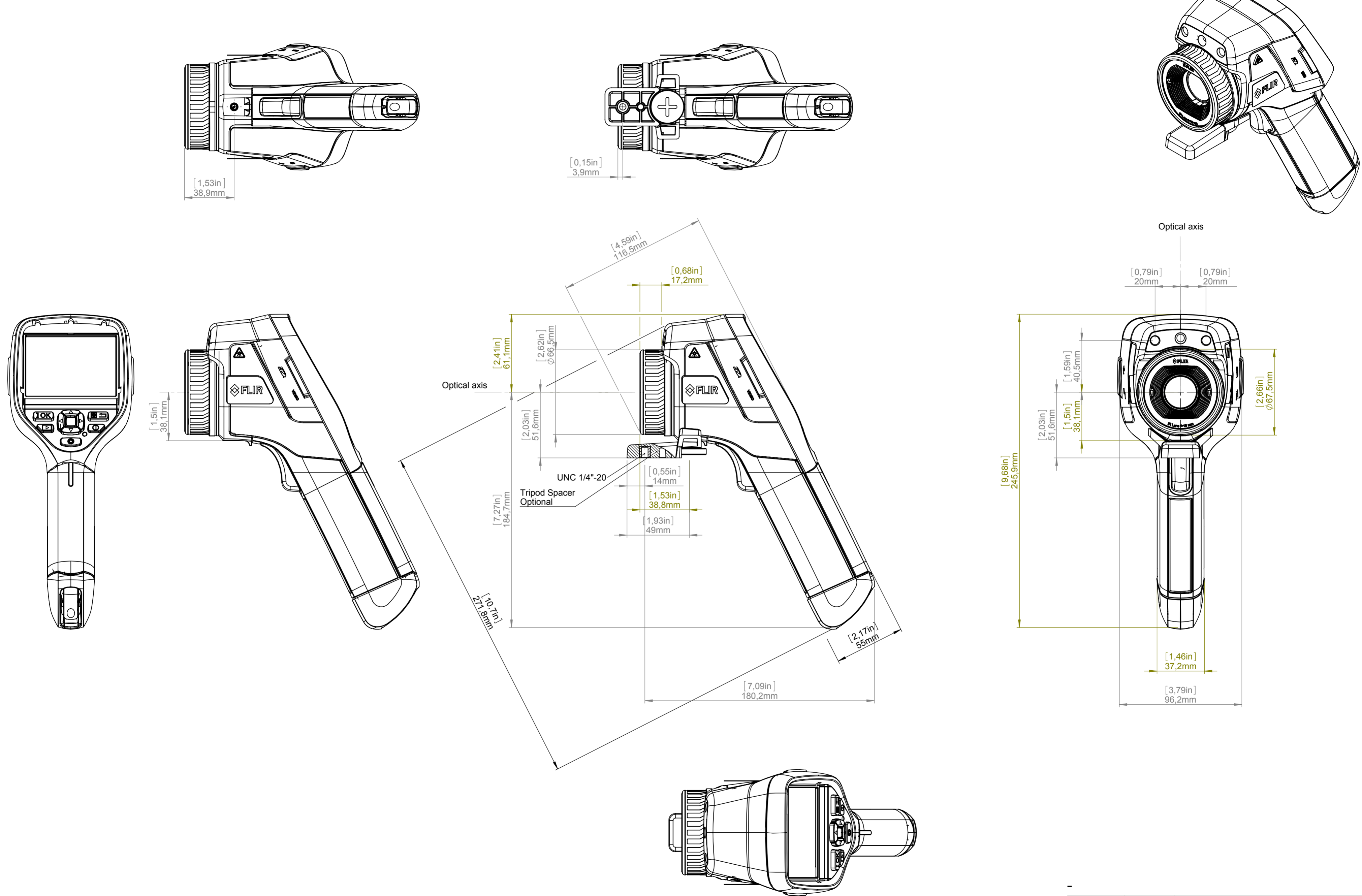

© 2012, FLIR Systems, Inc. All rights reserved worldwide. No part of this drawing may be reproduced, stored in a retrieval system, or transmitted in any form, or by any means, electronic, mechanical, photocopying, recording, or otherwise, without the prior written permission of FLIR Systems, Inc. Specifications subject to change without notice. Dimensions are based on nominal values. Products may be subject to regional market considerations. License procedures may apply. Product may be subject to US Export Regulations. Please refer to exportquestions@flir.com with any questions. Diversion contrary to US law is prohibited.

Modified 2012-04-18	Check CAHA	Drawn by R&D Thermography	
Denomination			
Basic dimensions FLIR Exx			Size A3 Scale 1:2 Sheet 1(4)
Drawing No. T126960			Size A

Camera with Lens IR f=10 mm (45°)

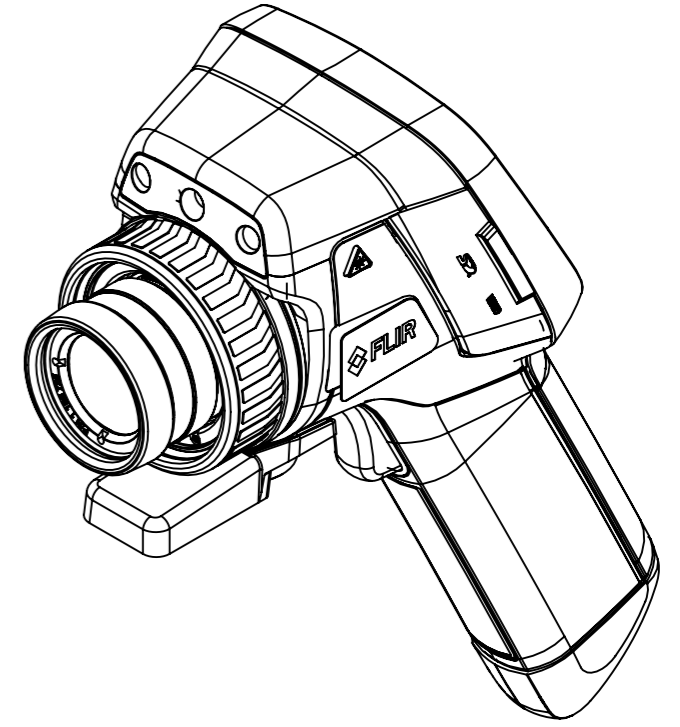
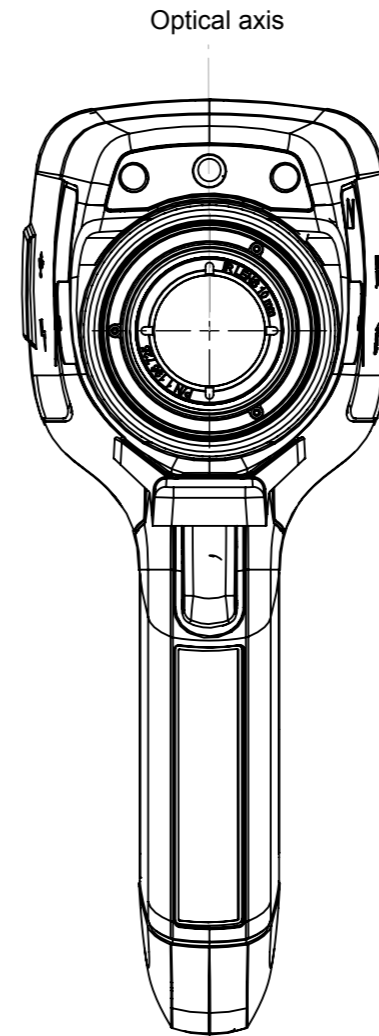
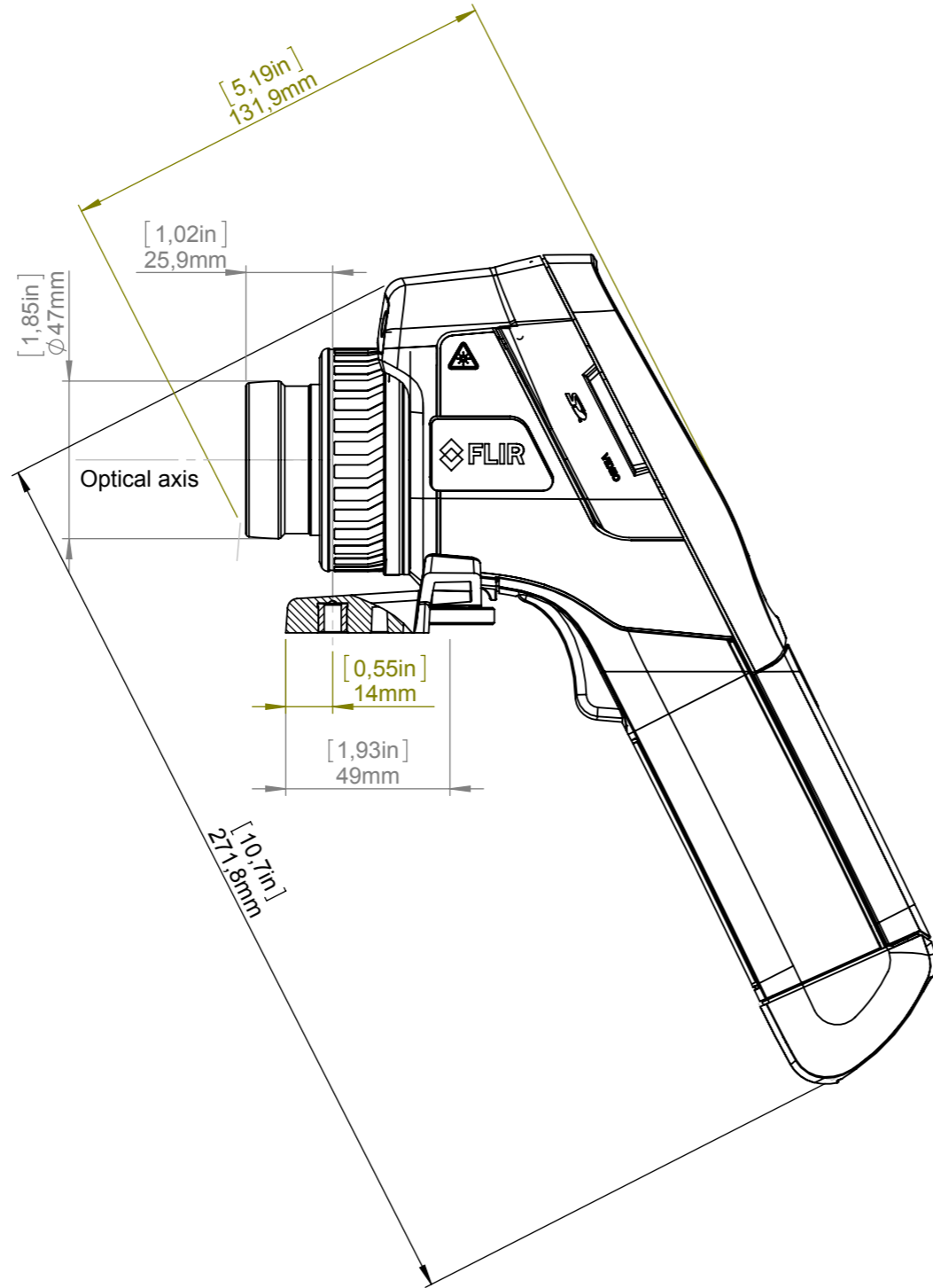
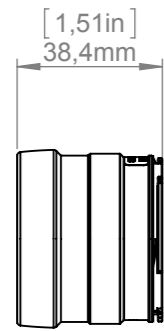

© 2012 FLIR Systems, Inc. All rights reserved worldwide. No part of this drawing may be reproduced, stored in a retrieval system, or transmitted in any form, or by any means, electronic, mechanical, photocopying, recording, or otherwise without written permission from FLIR Systems, Inc. Specifications subject to change without further notice. Dimensional data is based on nominal values. Products may be subject to regional market considerations. License procedures may apply. Product may be subject to US Export Regulations. Please refer to exportquestions@flir.com with any questions. Diversion contrary to US law is prohibited.

For additional dimensions see page 1

Modified 2012-04-18	Check CAHA	Drawn by R&D Thermography	
Denomination Basic dimensions FLIR Exx			
Drawing No. T126960			Sheet 2(4) Size A

Camera with Lens IR f=30 mm (15°)

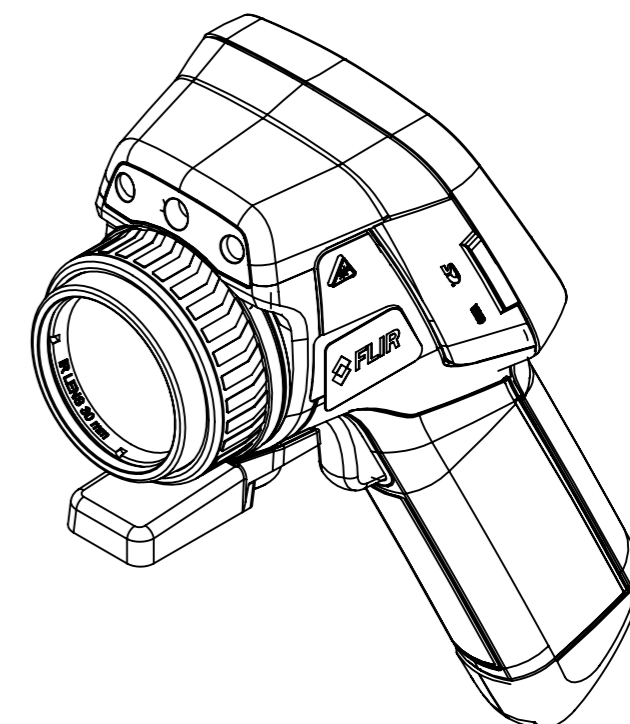
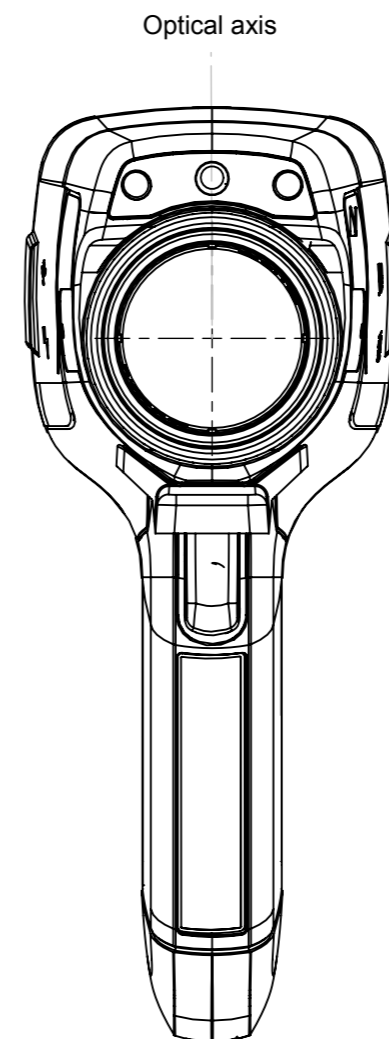
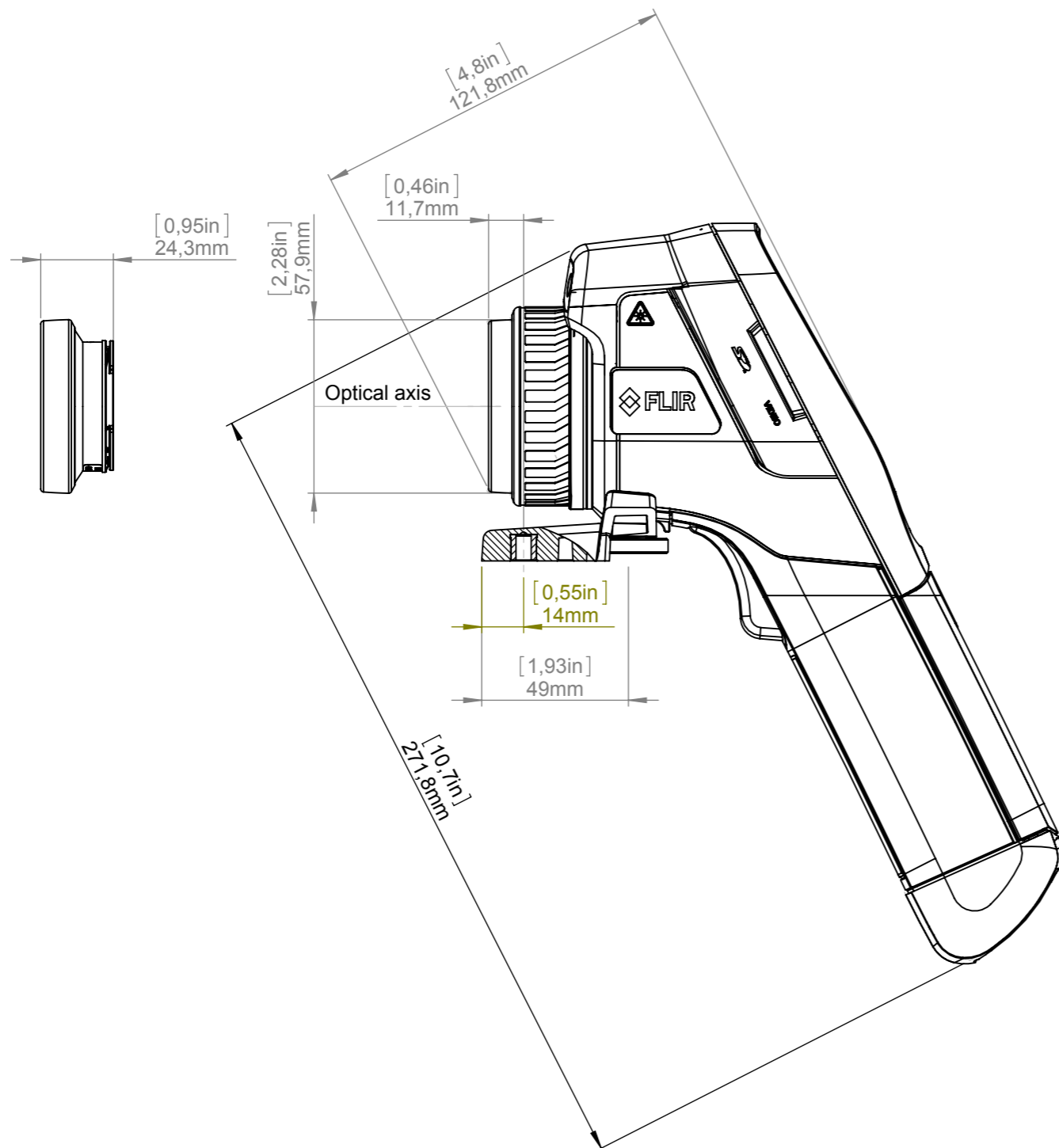

© 2012 FLIR Systems, Inc. All rights reserved worldwide. No part of this drawing may be reproduced, stored in a retrieval system, or transmitted in any form, or by any means, electronic, mechanical, photocopying, recording, or otherwise without written permission from FLIR Systems, Inc. Specifications subject to change without further notice. Dimensional data is based on nominal values. Products may be subject to regional market considerations. License procedures may apply. Product may be subject to US Export Regulations. Please refer to exportquestions@flir.com with any questions. Diversion contrary to US law is prohibited.

For additional dimensions see page 1

Modified 2012-04-18	Check CAHA	Drawn by R&D Thermography	
Denomination Basic dimensions FLIR Exx			
Size A3	Scale 1:2	Sheet 3(4)	
Drawing No. T126960	Size A		

Camera with Lens IR f=76 mm (6°) incl support

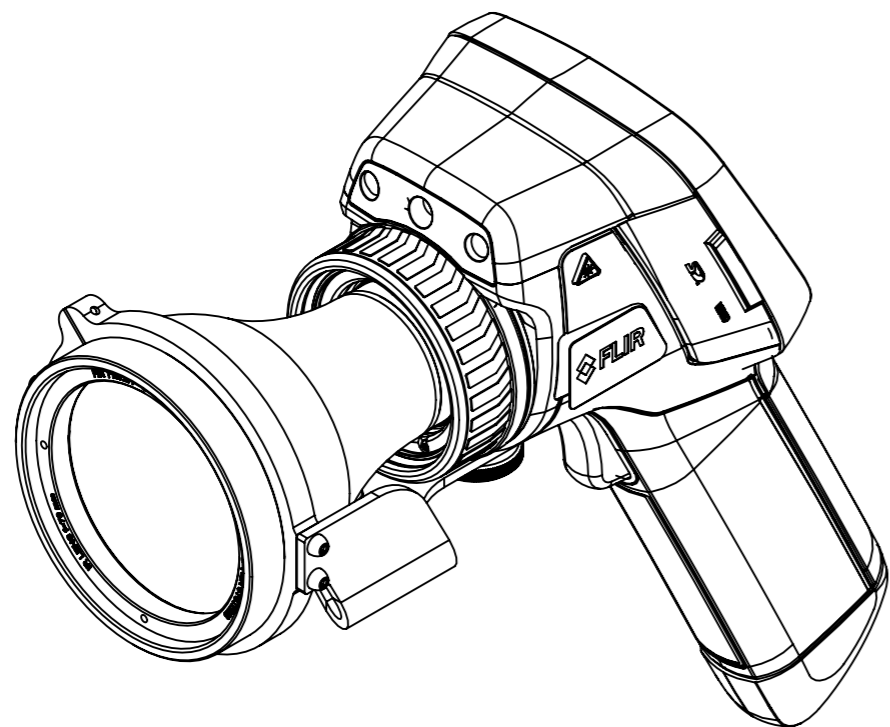
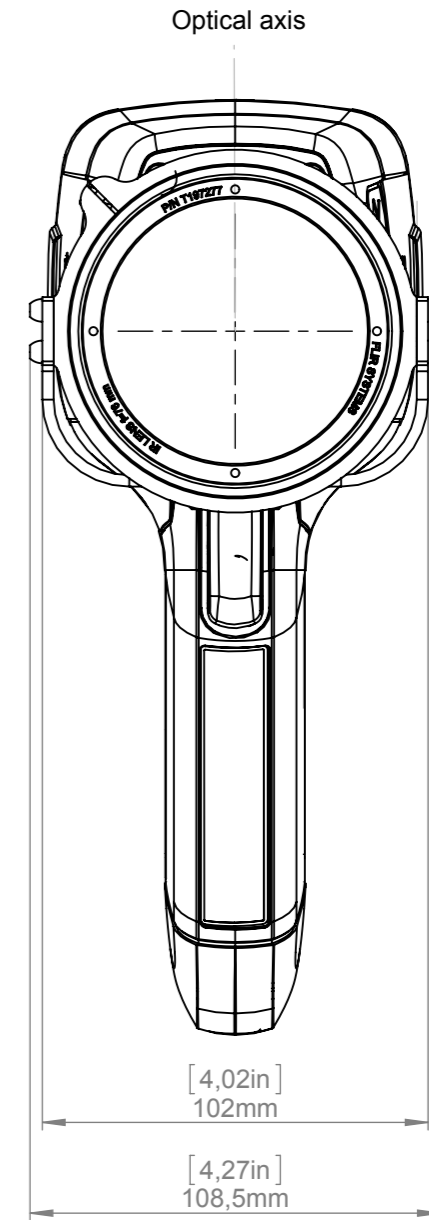
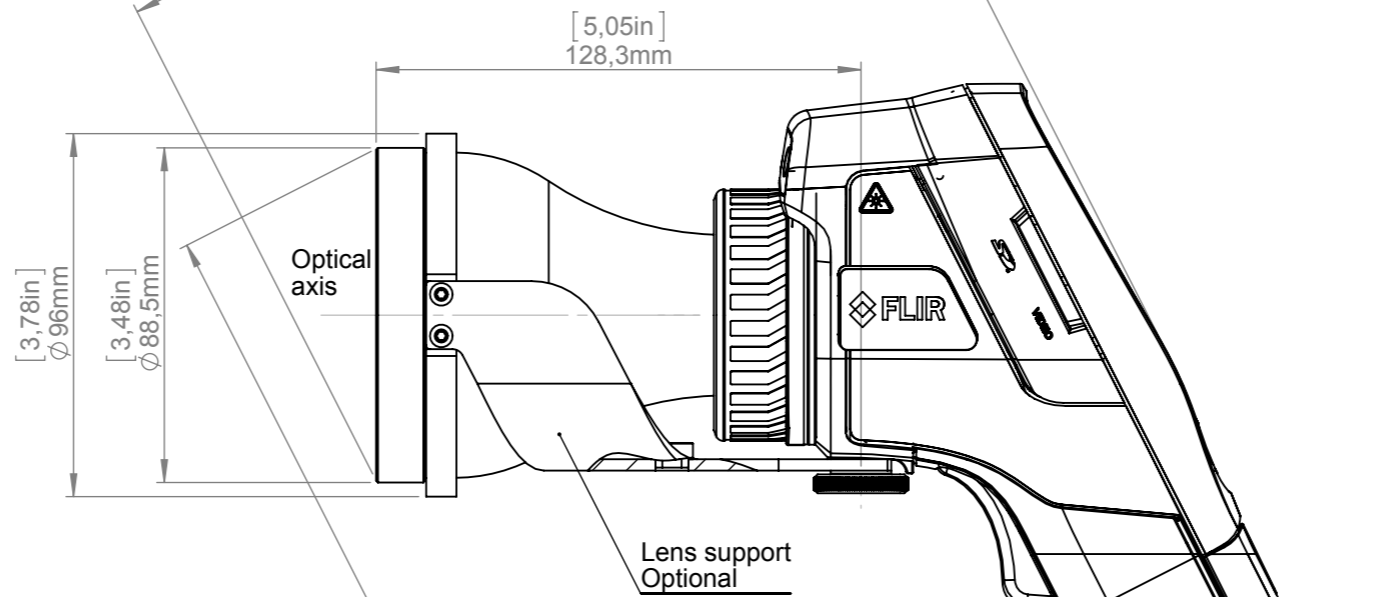
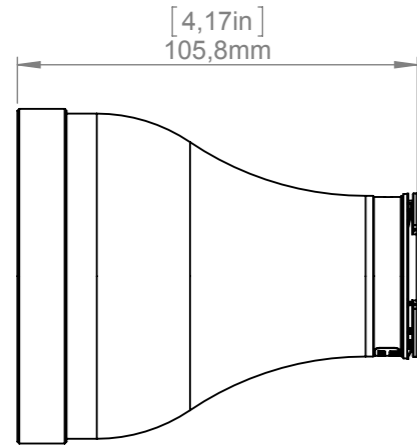

© 2012 FLIR Systems, Inc. All rights reserved worldwide. No part of this drawing may be reproduced, stored in a retrieval system, or transmitted in any form, or by any means, electronic, mechanical, photocopying, recording, or otherwise without written permission from FLIR Systems, Inc. Specifications subject to change without further notice. Dimensional data is based on nominal values. Products may be subject to regional market considerations. License procedures may apply. Product may be subject to US Export Regulations. Please refer to exportquestions@flir.com with any questions. Diversion contrary to US law is prohibited.

For additional dimensions see page 1

Modified 2012-04-18	Check CAHA	Drawn by R&D Thermography	
Denomination			
Basic dimensions FLIR Exx			Sheet 4(4) Size A